

POLY-TUFF SYSTEMS INTERNATIONAL

2250 E. Tropicana Ave
Suite 19-600
Las Vegas, NV 89119



Phone: (866) 977-8833
Fax: (800) 804-0182
Email: sales@polytuffus.com
Web: www.polytuffus.com

PSI Tech-Note

10/2/2008

Super Seal Tape - Expansion or Control Joint Waterproofing

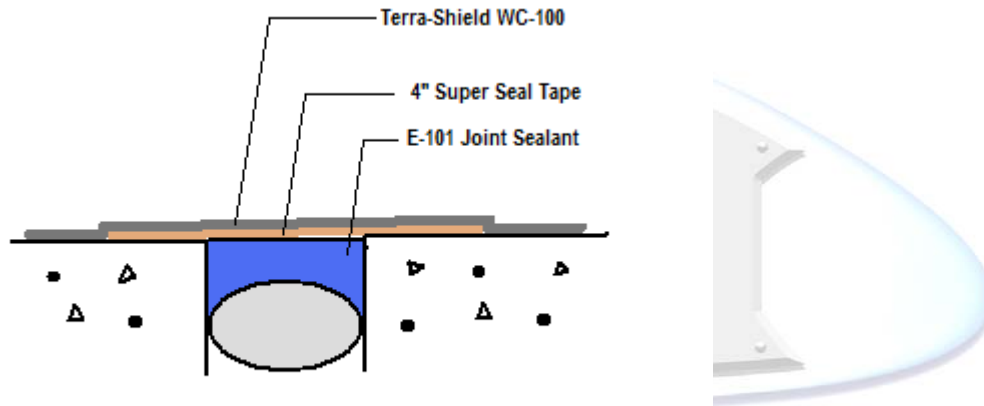

The above detail demonstrates the approved use of Super Seal Tape 4" over a control or expansion joint in a planter or below grade waterproofing condition. The Super Seal Tape must extend a minimum of 1 1/2" on both sides of the joint. The tape must be hand pressed into place leaving no fishmouths along the edges. If the texture of the surface is porous, uneven or slightly rough, it is recommended that Enviro-Grip #1, 2, or 5 primer is used to smooth out the surface area and allow a smooth surface for the tape to bond to the substrate.

If primer is used, it is recommended that the primer is firm and thumbprint tacky before applying the Super Seal Tape.

The product data sheets in the product data sheet section of the Poly-Tuff Binder or at www.polytuffus.com. Feel free to consult the related data sheet or call 866.977.8833 for further information.

Bob Clanton

Bob Clanton
National Sales Manager